



Tesla **TS65**1W XK-12

AC LED SMD Package

SPECIFICATION

CHIP-ARRAY-ON-CERAMIC TYPE SMD LED



Lynk Labs Technology packaged by **Intematix**



Contents:

1. Features	3
2. Applications	3
3. Mechanical Dimensions	3
4. Recommended PCB layout	4
5. Electrical & Optical Characteristics	5
6. Absolute Maximum Ratings	5
7. C.I.E. Chromaticity Coordinates & Bin Grade Diagram	6
8. Packaging.....	8
9. Cautions	10
10. Typical Electrical & Optical Characteristic Curves	13
11. Reliability and Average Lumen Maintenance	16



1. Features

- Specially designed for direct drive Alternating Current (AC) applications.
- Small Footprint: 6.5 × 6.5 × 0.95mm (LxWxH)
- 16 LED chip array provides uniform illumination and tight color binning
- High power: 1.0W
- Compliant with RoHS directive

2. Applications

- Signage
- Indoor/Outdoor General Illumination
- Retail and Display Illumination
- Linear Lighting applications

3. Mechanical Dimensions

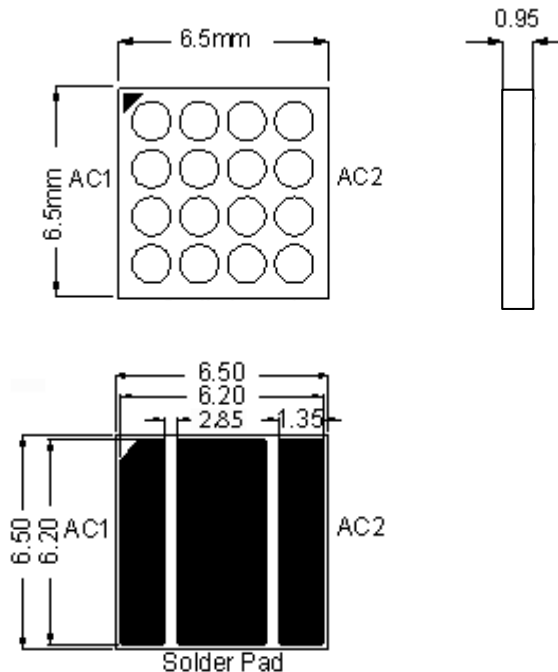

Notes :

1. All dimensions are in millimeters.
2. Tolerance is ±0.20mm unless otherwise noted.



4. Recommended PCB layout

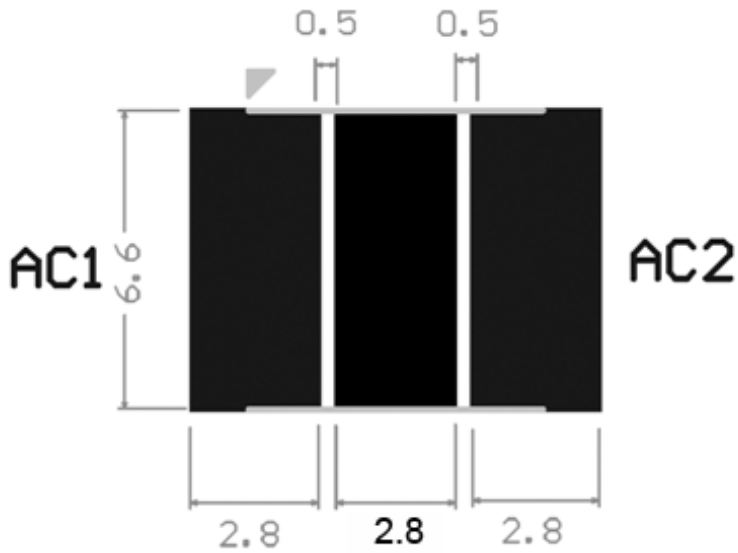

Note :

1. All dimensions are in millimeters.



5. Electrical & Optical Characteristics

ITEM	SYMBOL	CONDITION	UNIT	MIN.	TYP.	MAX.
AC Forward Current	I _f	V _f =12.0Vrms	mArms	70	80	130
Viewing Angle	2θ _{1/2}		deg		110	
Thermal Resistance	R _{θj-c}	I _f =80mArms	°C/W		11	
Luminous Flux (5000K)	Φ	V _f =12.0Vrms	lm	55	60	65

(Thermal Pad Temperature @25°C)

*Measurement Uncertainty of the Luminous Flux: ± 10%

*Values given are for specified drive current at 25°C junction temperature.

6. Absolute Maximum Ratings (@ Ta=25°C)

ITEM	SYMBOL	ABSOLUTE MAXIMUM RATING	UNIT
Power Dissipation	P _d	1200	mW
A.C. Current	I _f	120	mArms
Operating Temperature	T _o	-25 ~ +100	°C
Storage Temperature	T _s	-40 ~ +100	°C
Soldering Temperature(Reflow)(*1)	T _{sld}	240	°C
Soldering Temperature(Hand)	T _{sld}	370	°C

(Thermal Pad Temperature @25°C)

*1: Reflow method: 1.6mm from body for 5 seconds not exceeding the maximum temperature.



7. CIE Chromaticity Coordinates & Bin Grade Diagram

RANK: CW & NW

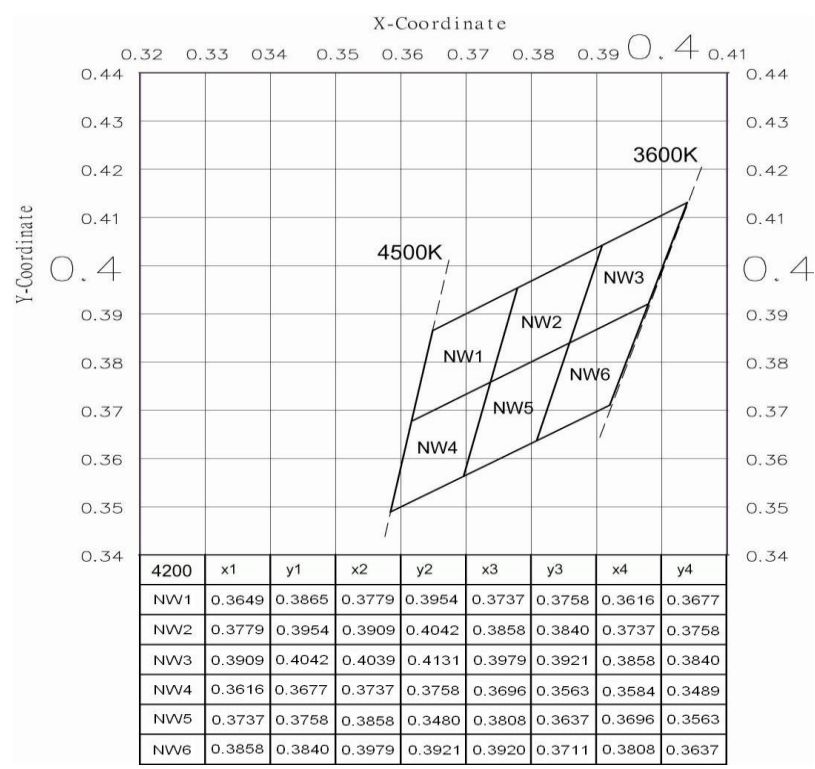
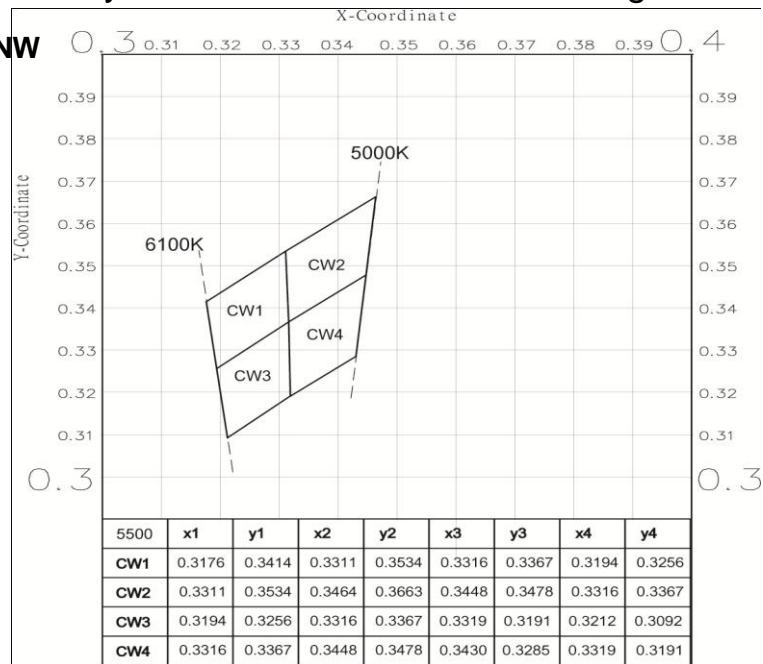

*Measurement uncertainty of the color coordinates: ± 0.01



7. CIE Chromaticity Coordinates & Bin Grade Diagram

RANK: WS & WT

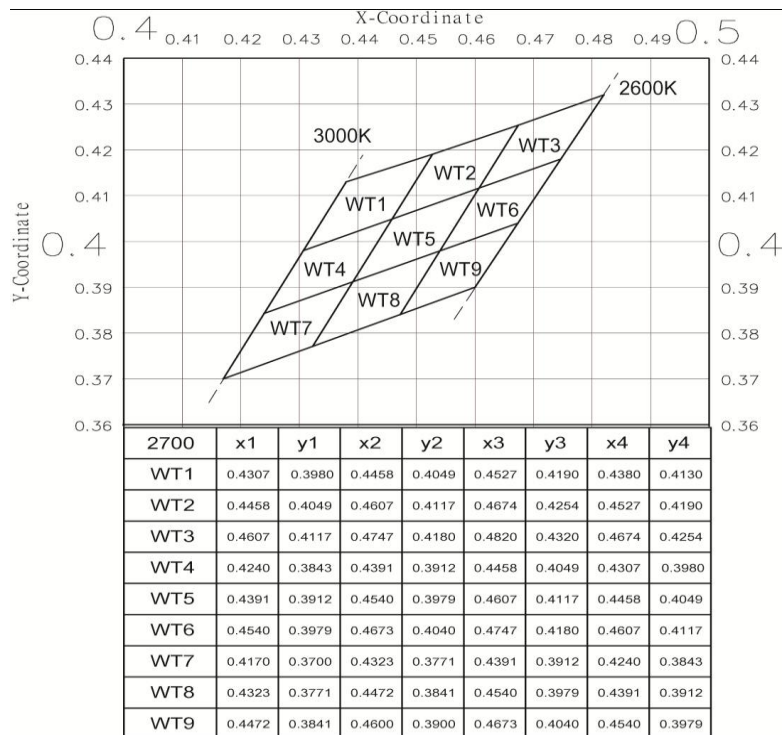
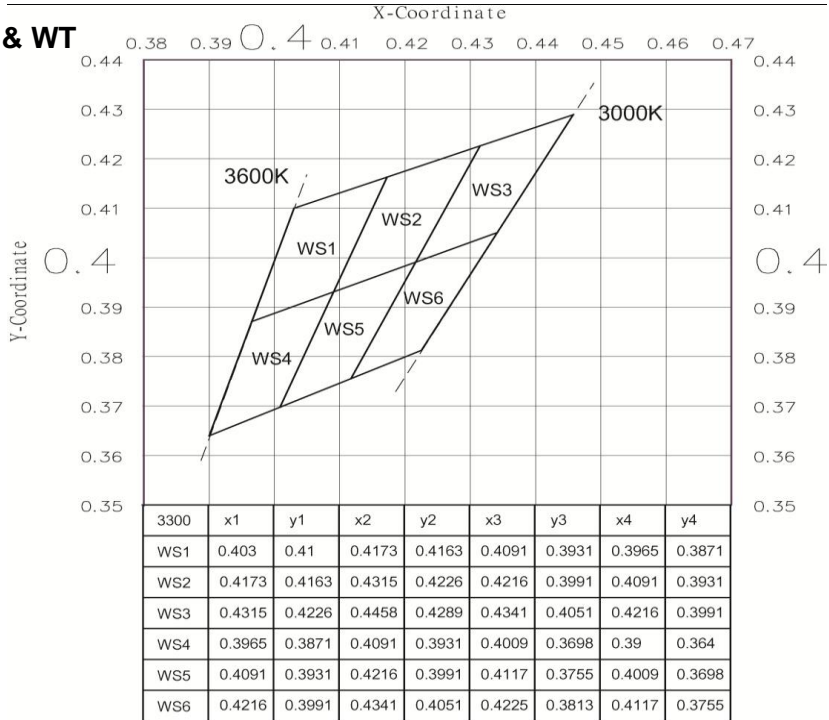

*Measurement uncertainty of the color coordinates: ± 0.01



8. Packaging

Tape and Reel in 12mm tapes.

According to the total delivery amount, cardboard boxes will be used to protect the LEDs from mechanical shocks during transportation.

The boxes are not water resistant and therefore must be kept away from water and moisture.

8.1 Tape and Reel Dimensions:

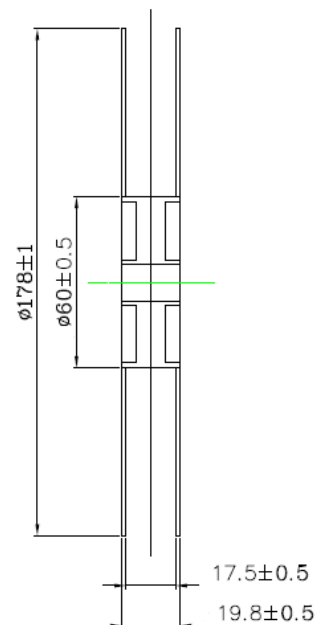
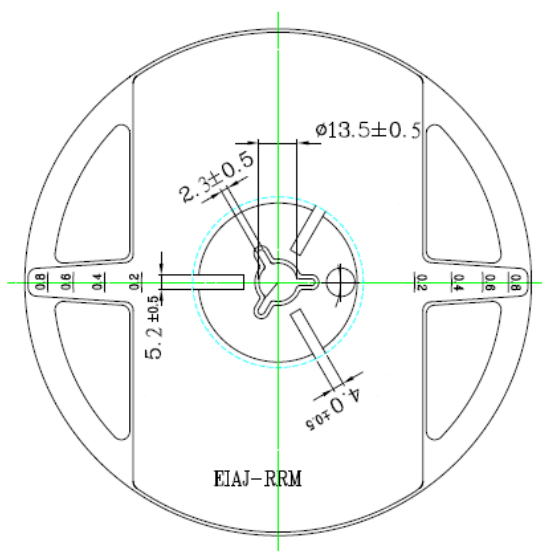
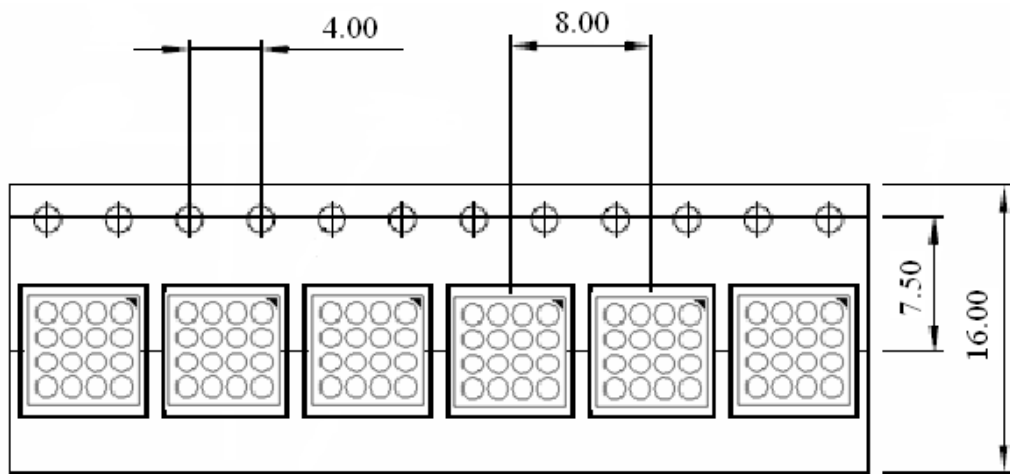



8.2 Cardboard Boxes



(Max. 1,000 Pieces SMD a reel)

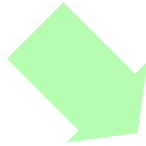
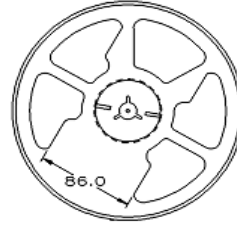

(Max. 4 reels)

Sheet box

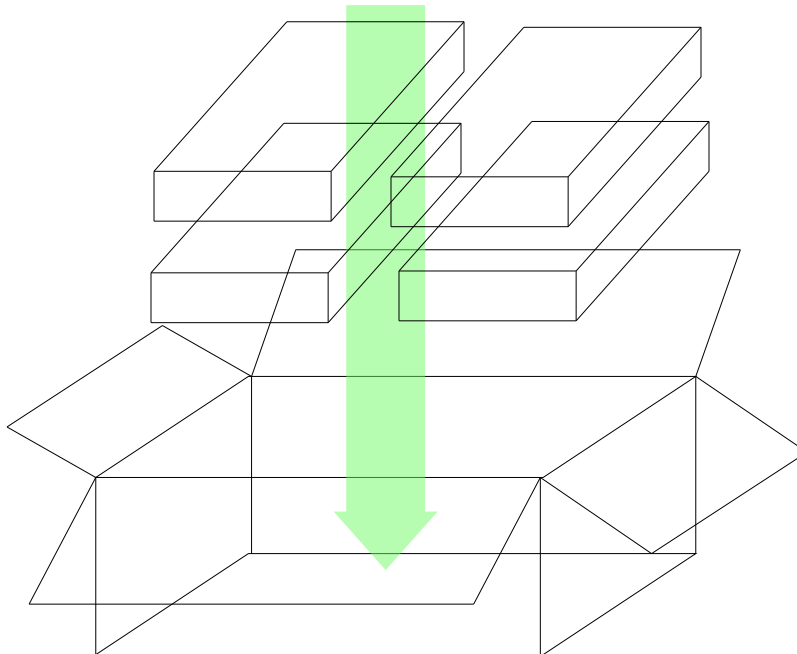
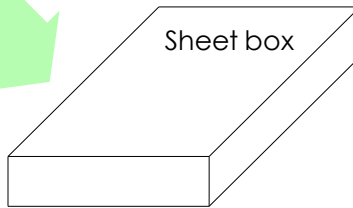



9. Cautions

9.1 Moisture Proof Package

When moisture is absorbed into the SMT package it may vaporize and expand during soldering. There is a possibility that this can cause exfoliation of the contacts and affect the optical characteristics of the LEDs. For this reason, a moisture proof package is used to keep moisture to a minimum in the package.

9.2 Storage

Recommended storage environment:

Temperature: 5°C ~ 30°C (41°F ~ 86°F)

Humidity: 60% RH Max.

Use within 7 days after opening sealed vapor/ESD barrier bags.

If LEDs remain unused, they should be stored in moisture proof packages, such as sealed containers with packages of moisture absorbent material.

9.3 Soldering

Reflow Soldering

Recommend use of upper and lower heater type reflow furnace 260°C Max for up to 10 seconds, one time only. Pre-heat is 200°C Max for up to 2 minutes Max. In case of screen-printing, keep metal mask thickness between 0.2mm and 0.3mm.

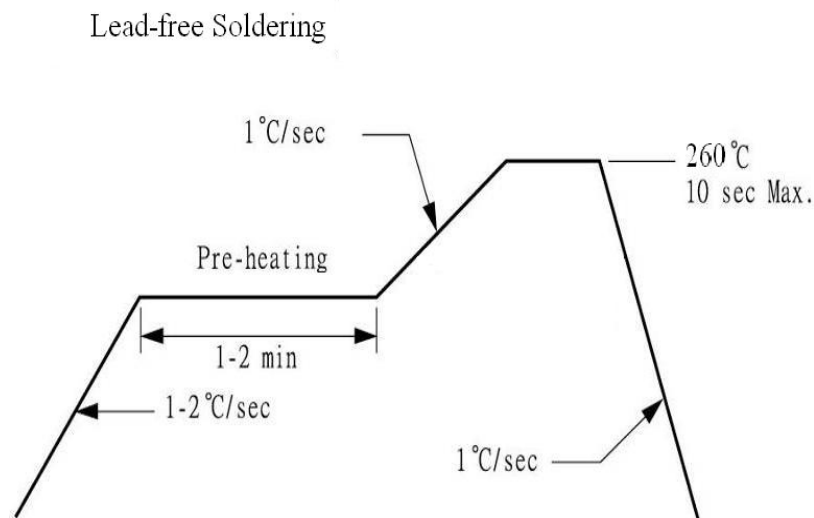



Manual Iron Soldering (NOT RECOMMENDED)

Use SN60 solder with silver content.

Use 25W soldering iron at 370°C (698°F) Max for 3 seconds or less.

The soldering time and temperature will vary with different LED thermal dissipation base.

Must not touch top resin portion of SMD LED by heated soldering iron.

Repair should not be done after the LEDs have been soldered. If repair is unavoidable, a double-head soldering iron should be used.

9.4 Heat Generation

Thermal design of the end product is of paramount importance. Heat generated by the LED must be considered in system design. The coefficient of temperature increase per input electric power is affected by the thermal resistance of the circuit board and density of LED placement on the board, as well as other components. It is necessary to avoid intense heat generation and operate within the maximum ratings given in this specification.

The operating current should be derated if ambient temperature is to exceed recommended value in this datasheet.

9.5 Cleaning

It is recommended that isopropyl alcohol be used as a solvent for cleaning the LEDs. When using other solvents, it should be confirmed beforehand whether the solvents will damage the LED.

Avoid using organic solvents. Surface condition of this device may change when organic solvents such as trichloroethylene or acetone are applied.

Do not clean the LEDs by the ultrasonic method. When it is absolutely necessary, the effect of ultrasonic cleaning on the LEDs depends on factors such as ultrasonic power, baking time and assembled condition. Before cleaning, a pre-test should be done to confirm whether any damage to the LEDs will occur.



9.6 Handling Instructions of Silicone Resin LEDs

Mechanical stress on the surface should be minimized as much as possible during handling.

Sharp objects of any type should not be used to avoid piercing the sealing compound.

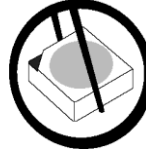

OK

9.7 Other

No responsibility accepted for any damage caused due to use of LEDs at conditions exceeding specifications.

These LEDs are designed and manufactured for use in typical consumer applications. It is recommended to consult us in advance if user's application requires any particular quality or reliability which concerns human life. Examples would be medical equipment, aerospace applications, traffic signals, safety system equipment and so on.

The LED light output is strong enough to injure human eyes. Precautions must be taken to prevent looking directly at the LEDs with unprotected eyes for more than a few seconds.

The appearance and specifications of the product may be modified for improvement without notice.



10. Typical Electrical & Optical Characteristic Curves

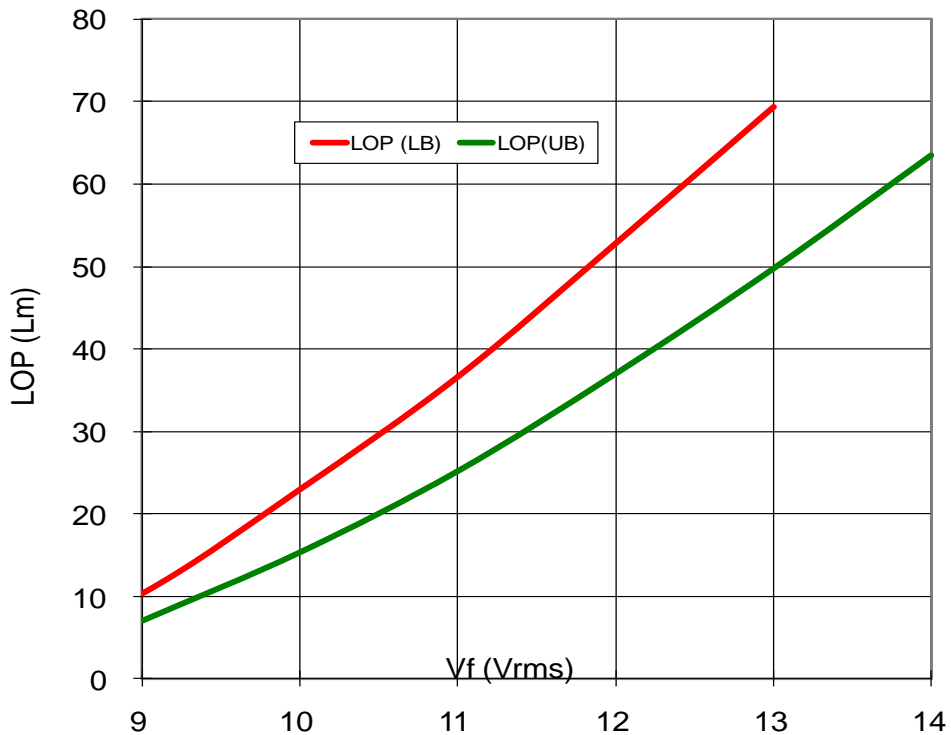
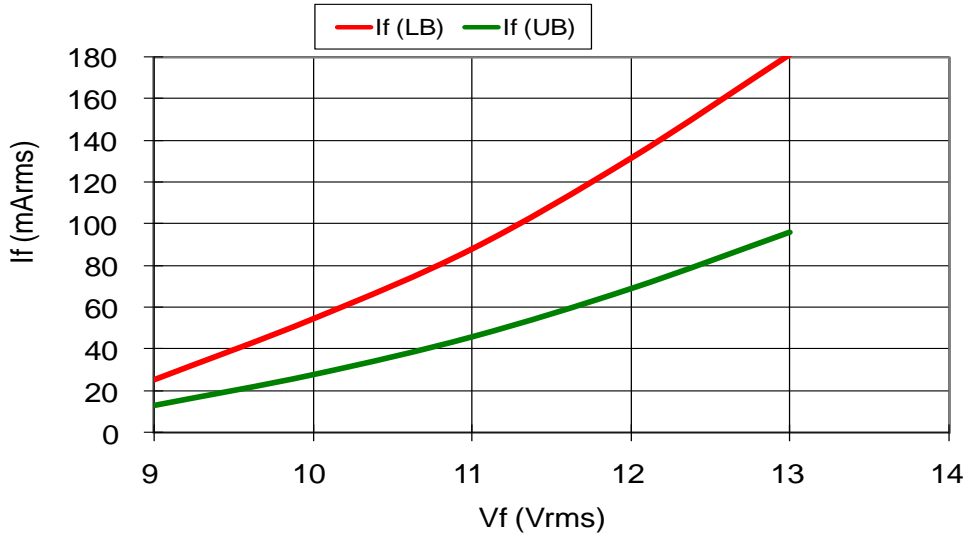



10. Typical Electrical & Optical Characteristic Curves

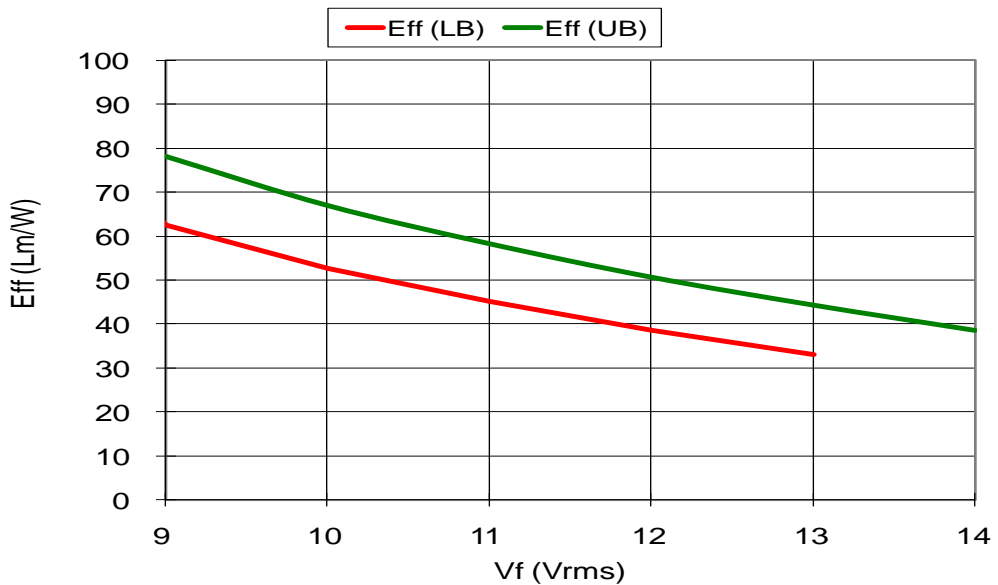
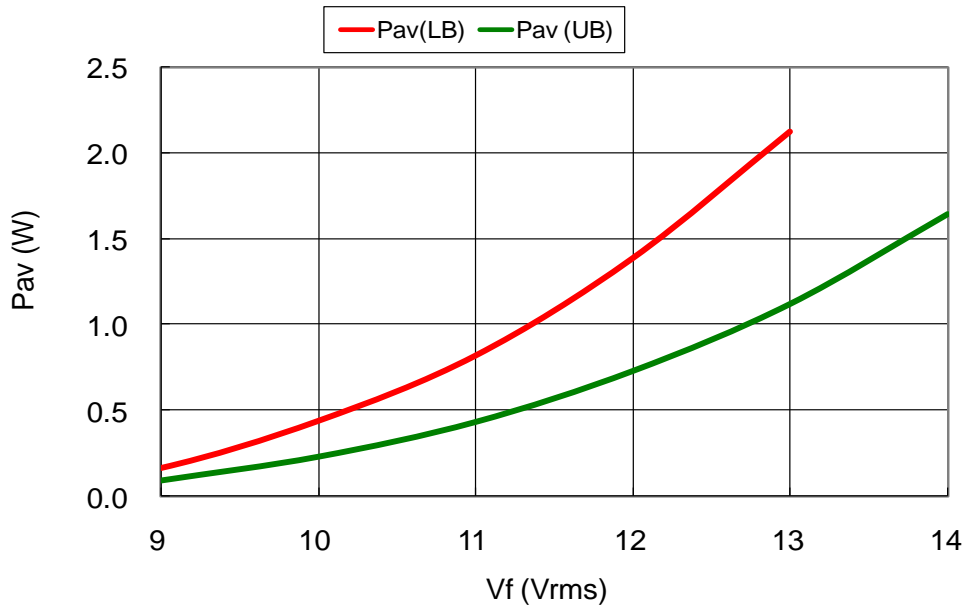



10. Typical Electrical & Optical Characteristic Curves

Wavelength Characteristics - CW/NW

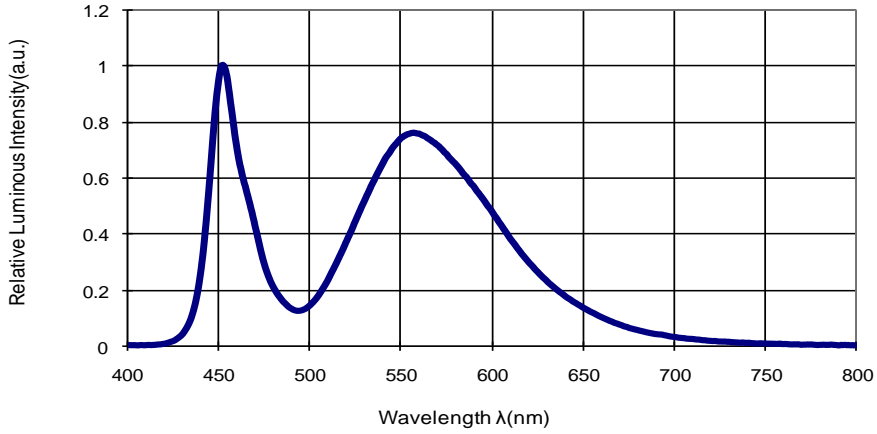

Wavelength Characteristics - WS/WT

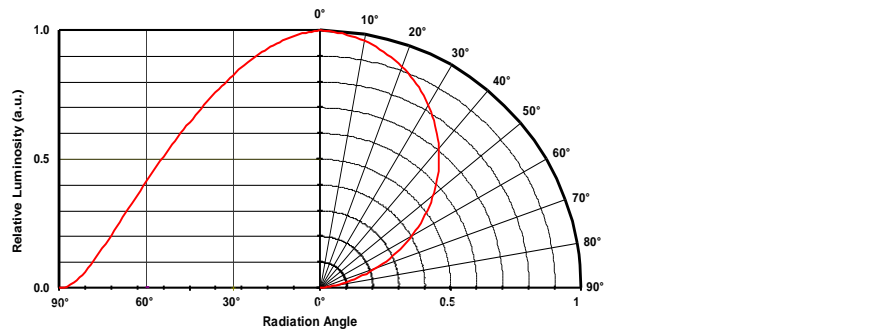
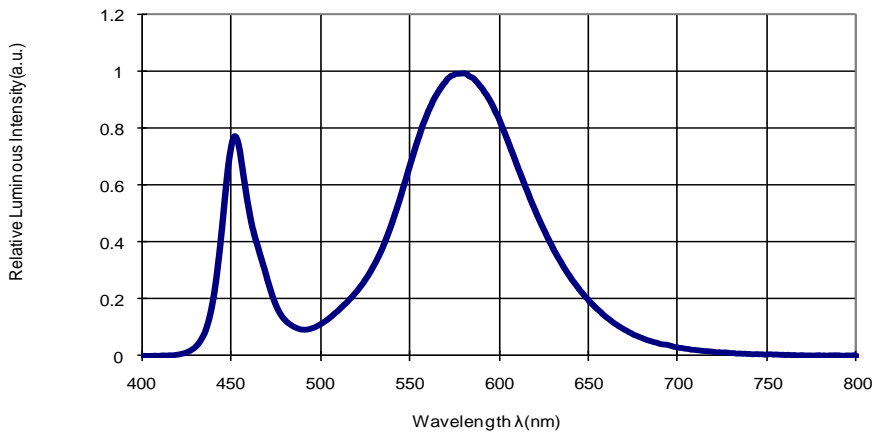



11. Reliability and Average Lumen Maintenance

Before releasing new products the manufacturer puts a representative product sample set through an entire suite of qualification tests, including the most stressful test for high power LEDs, the Wet High-Temperature Operating Life (WHTOL) test at 85°C/85%RH for 1000 hours at the specified operating current.

LED lifetime has been extrapolated based on the accumulated operating and accelerated aging data. Based on this data, the manufacturer projects that the LED products will deliver, on average, 70% lumen maintenance at 50,000 hours of operation at the specified operating current, provided that the case temperature is maintained at or below 80°C.